

MAISON&OBJET PARIS 18-22 JAN 2024. 30th ANNIVERSARY

Pistore Marmi x McGannon Saad

*THEBES STOOL*

Hall 7 \_ Stand E170  
Paris Nord Villepinte Exhibition Centre





**Press Release / THEBES**

---

**Thebes stool & chair, Pistore Marmi 2024**

**Designed by McGannon Saad**

Introducing the “Thebes” stool, a seamless blend of past and present. This stool embodies the essence of Italian marble craftsmanship and modern machine carving.

McGannon Saad wanted to emphasize the inherent qualities of marble as a material, as the company Pistore Marmi has been renowned for its natural stone since the 1960’s in the Veneto region. The monolithic form showcases the pure beauty of each stone’s metamorphosis, creating poetic textures and stories. With a curved seat for added comfort, it draws inspiration from archaic period’s objects, hence the name Thebes.

The durability of stone makes it ideal for both indoor and outdoor use, while it effortlessly integrates into contemporary spaces. It comes in two versions – a low-back chair and a stool – with finish options in Rosso Verona, Travertino, Bianco Carrara, or Nero Marquina.

–

MAISON&OBJET PARIS / 30th anniversary  
18-22 JAN 2024  
Hall 7 - Stand E170  
Paris Nord Villepinte Exhibition Centre

photo\_Cristina Romanello





***THEBES STOOL***

---

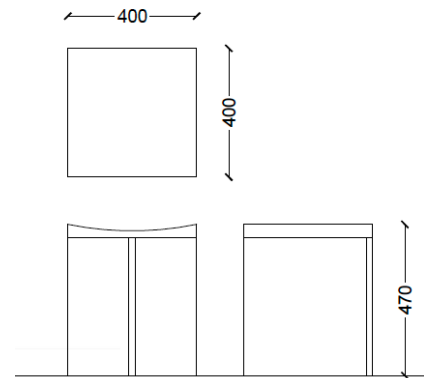





### *THEBES CHAIR*

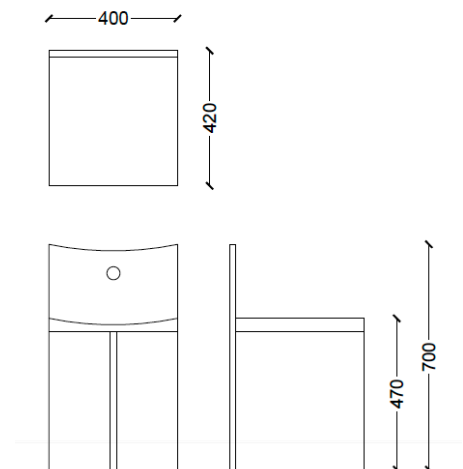



## ***Bio* \_ MCGANNON SAAD**

---

**MGGANNON SAAD** was founded by Jules McGannon and Nour Abi Saad on the French Riviera. Their philosophy embraces diversity, cultural mixity, and design thinking. They operate in the fields of interior design, product design, graphics, and exhibitions. They showcased their Seto collection at SaloneSatellite 2023 curated by Marva Griffin, and were selected by House & Garden UK part of the annual "Design 100" publication.

**Jules McGannon's** roots are French, American/Irish. He earned a master's degree in Product Design from Domus Academy in Milan, after completing a master in Interior Architecture from ESAM in Paris. He had a multidisciplinary experience at Continuum and FutureBrand. He was part of the design team led by Piero Lissoni, where he developed high-end product design for Kartell, Fendi Casa, Glas Italia, De Padova, Porro, and many more.

**Nour Abi Saad** is Lebanese, she obtained a laurea magistrale in Interior Design from Politecnico di Milano. She was part of Mario Bellini Architects, where she worked on museum & exhibition design in Milan. She tutored the Master in Interior & Living Design at Domus Academy. She collaborated with Lissoni & Partners as Interior Designer on international projects, such as SLS Red Sea Hotel by architect Foster & Partners, and Holland Park Gate in Kensington London.





*“MARBLE WITH AN ARTISAN SOUL.”*

## *About us* \_ PISTORE MARMI

---

### TODAY

We are contemporary tailors and marble is our fabric. In every project we blend craftsmanship with creativity and technological innovation, producing tailor-made, unique and exclusive solutions that meet the needs of international and local customers.

Alongside our artisan approach we offer a complete service for architects and interior designers, ranging from design and selection of the most suitable types of marble right through to assistance with installation.

### OUR HISTORY

Founded in 1960 by the young Ferdinando Pistore, at the time a stonecutter and artisan and today Chairman of the company, Pistore Marmi is now managed by the second generation. The strong link with Veneto and its cities of art and the famous Palladian Veneto Villas is a daily source of inspiration for creating beautiful and exclusive residences and hospitality venues in Italy and worldwide.

In the words of Noè, CEO of Pistore Marmi:

“You need to have an inside knowledge of marble, to feel it and understand it in order to transform and interpret it. This is why I enjoy matching all aspects of the marble with my customers’ desires. It’s a hugely gratifying experience, involving me personally in every project.”

We collaborated with Luca Scacchetti, Marcelo Albini, Bettazzi+Percoco, and most recently with Sfero Design and McGannon Saad with products showcased at Maison&Objet 30th anniversary.