

ALAN LOUIS

Alan Louis, born in Brittany in 1992, ex-officer of the Merchant Navy, is a young self-taught draughtsman, designer and ceramist. He began his artistic career by exhibiting his works centered around the wild animal. He has always been sensitive to the aesthetics of interiors, and his taste for renovation and decoration developed and asserted itself. In 2021, between Lisbon, Paris and Brittany, he created his own brand of objects: benches, tables, lighting, vases, candlesticks and candles... Through ceramics, Alan Louis captures the special essence of raw, natural elegance.



THE BRAND

In the autumn of 2021, Alan Louis created his eponymous brand **ALAN LOUIS**.

Driven by a lifelong desire and need to create, Alan Louis didn't know how to unleash this creative fibre: writing, playing an instrument, stacking bricks... With a thousand thoughts a second, a move to Portugal and a bit of chance, he decided to take up ceramics.

« With clay, everything is both possible and uncertain... When we plunge our hands into it, thoughts flow from your mind, creating images and shapes that slip through the fingers and infiltrate the material. Ideas materialize life. It's magical, but during the firing in the kiln, it sometimes explodes, then comes the disappointment, and we want to stop everything.

We tell ourselves that the clay doesn't want us.

We persevere and then it works. Over time, we tame it. It's a material in motion until the object is fired and cooled. One day everything will line up perfectly and the next one nothing will work. With ceramics, we love each other and we hate each other.

It's that elusiveness that I like.»

Like the living sculptures he shapes, the contours and curves of his objects evoke stories. Each piece is unique, numbered, signed and hand-modelled in chamotte stoneware, a clay fired several times between 900 and 1400 degrees. During this process, the object achieves a solidity akin to that of stone. The objects are revealed through assembly, modelling, sculpting and different firings. Curves of clay sprinkled with jewels: benches, tables, vases, lights, candlesticks, candles and, coming soon, porcelain chandeliers and basins.

With Alan Louis, nothing is set in stone: wood, metal, glass... are all welcome in this creative journey without borders. Through his objects, Alan Louis blows an ever stronger wind of poetry, freedom and simplicity. These are unique objects that challenge codes and preconceived ideas. Opposites come together to create duality, as in the minimalist form of a bench combined with the extravagance of spikes.

« I experience a multitude of feelings that I want to convey through different fields. For me, art and design communicate through the link that is creativity. I use them to express my moods and desires.»

MAISON & OBJET

Alan Louis will be presenting his new collection of furniture and objects
from 18 to 22 January 2024 at Maison & Objet in Paris.

The designer joins the finest names in decoration and design in the SIGNATURE area at Maison & Objet (hall 7 - area C91),
where iconic designs, beautiful materials and unique pieces offer furniture and home furnishings a blend of luxury, audacity and elegance.

BENCHES



« I was sitting on a corner of a rock. From the top of this foamy cliff, I could see the bottom of the sea. Their pale blackness evoked an immense void teeming with curiosities. For the first time, I perceived the most inspiring images from these ancient quarries worked by the ocean. A world was emerging... treasures. »



THE PONTE BENCH



THE CABO BENCH









THE JÚPITER BEIGE BENCH







THE MERCÚRIO BENCH



THE MÃO BENCH

« There is what we see and what we don't see in an object. What it evokes, what it reminds us of. The secrets of a story that sway in each of us. Travelling for a few tiny seconds would be perfect. Images that come and go. A furtive and tasty whole, almost frustrating. We would like more of them, memories, thoughts and old words written by people from the past. As long as it remains unique. »





THE JÚPITER BLACK BENCH

TABLES

« The table, that fabulous object on which we place everything. Our joys, our sorrows, a bunch of keys, our flattened hands and our big decisions, a blank sheet, a coffee and the bottom of our pockets. Our latest novel surrounded by our two elbows, which it supports when boredom arises. We lay down some laughter and arm wrestling on it. A burning candle, a glass of wine, pencils and letters...And even our love. »



THE REI TABLE





THE JOIA TABLE

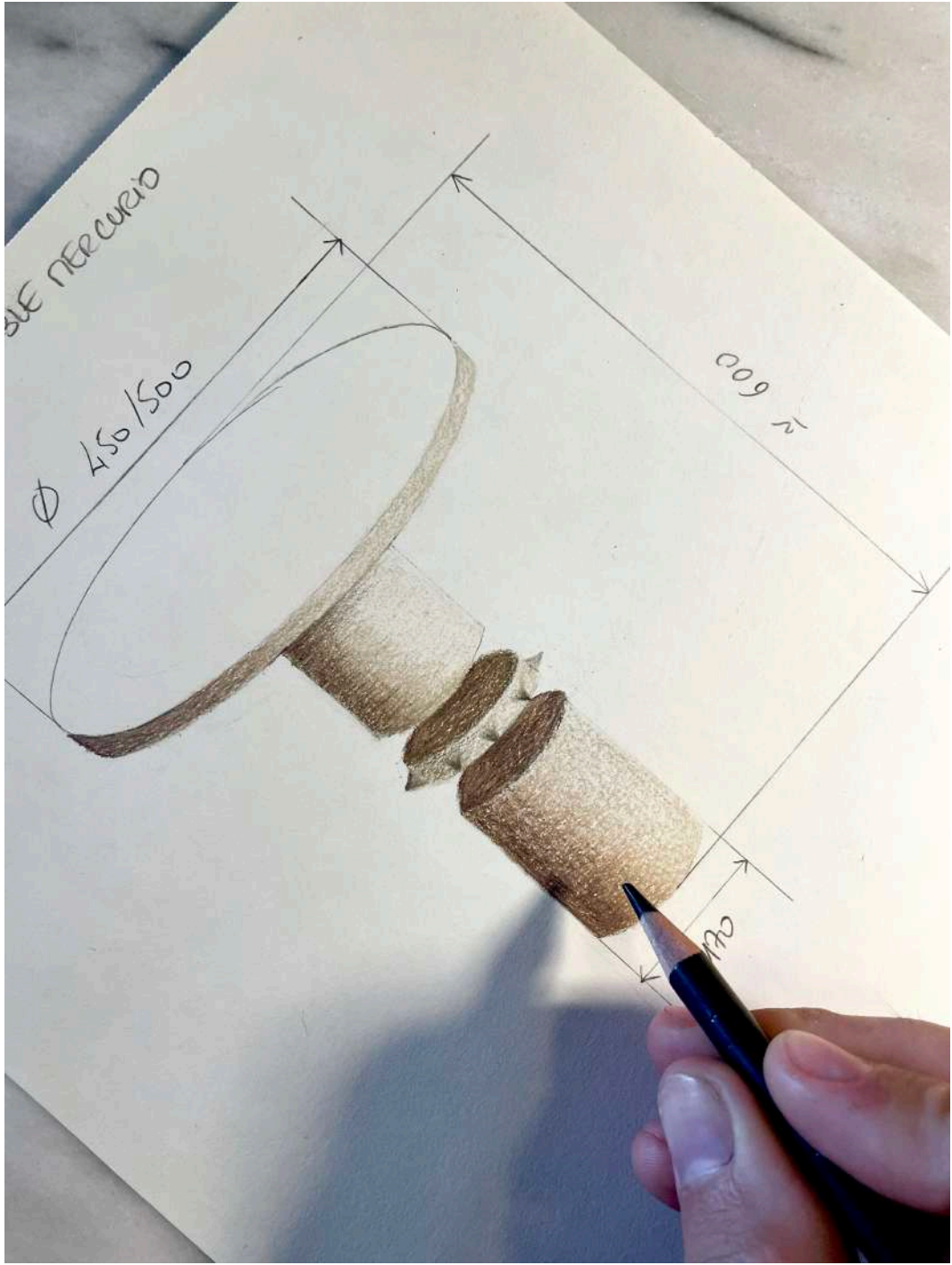



THE MERCÚRIO TABLE

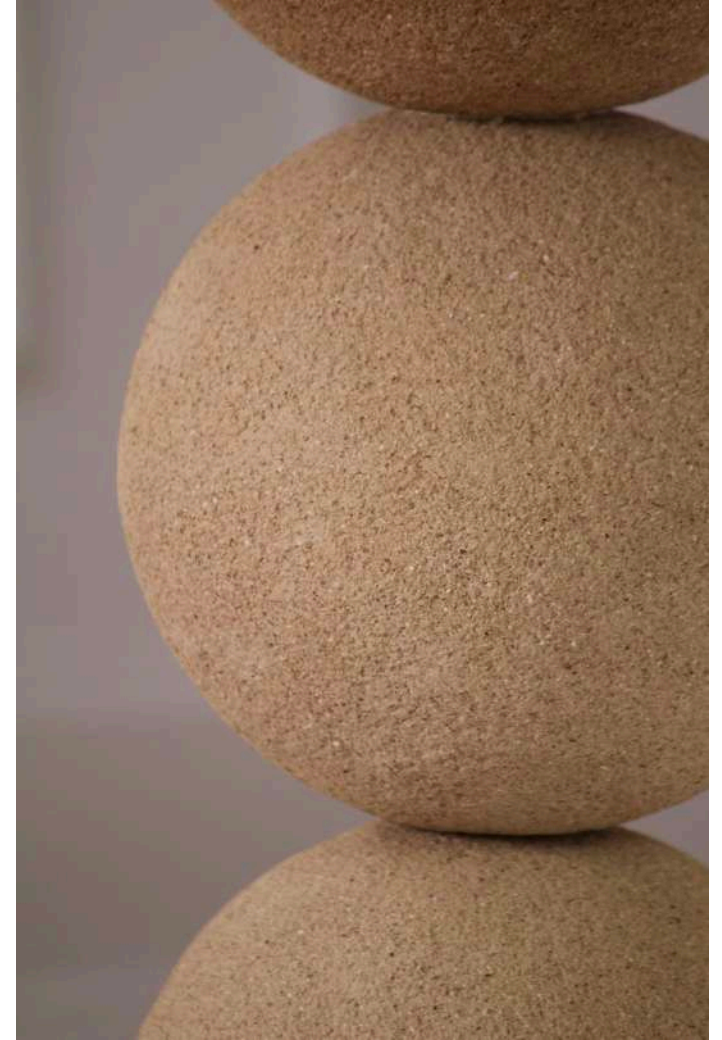

THE JÚPITER TABLE



THE TITÄ TABLE



THE SOHO TABLE



THE APOLO TABLE

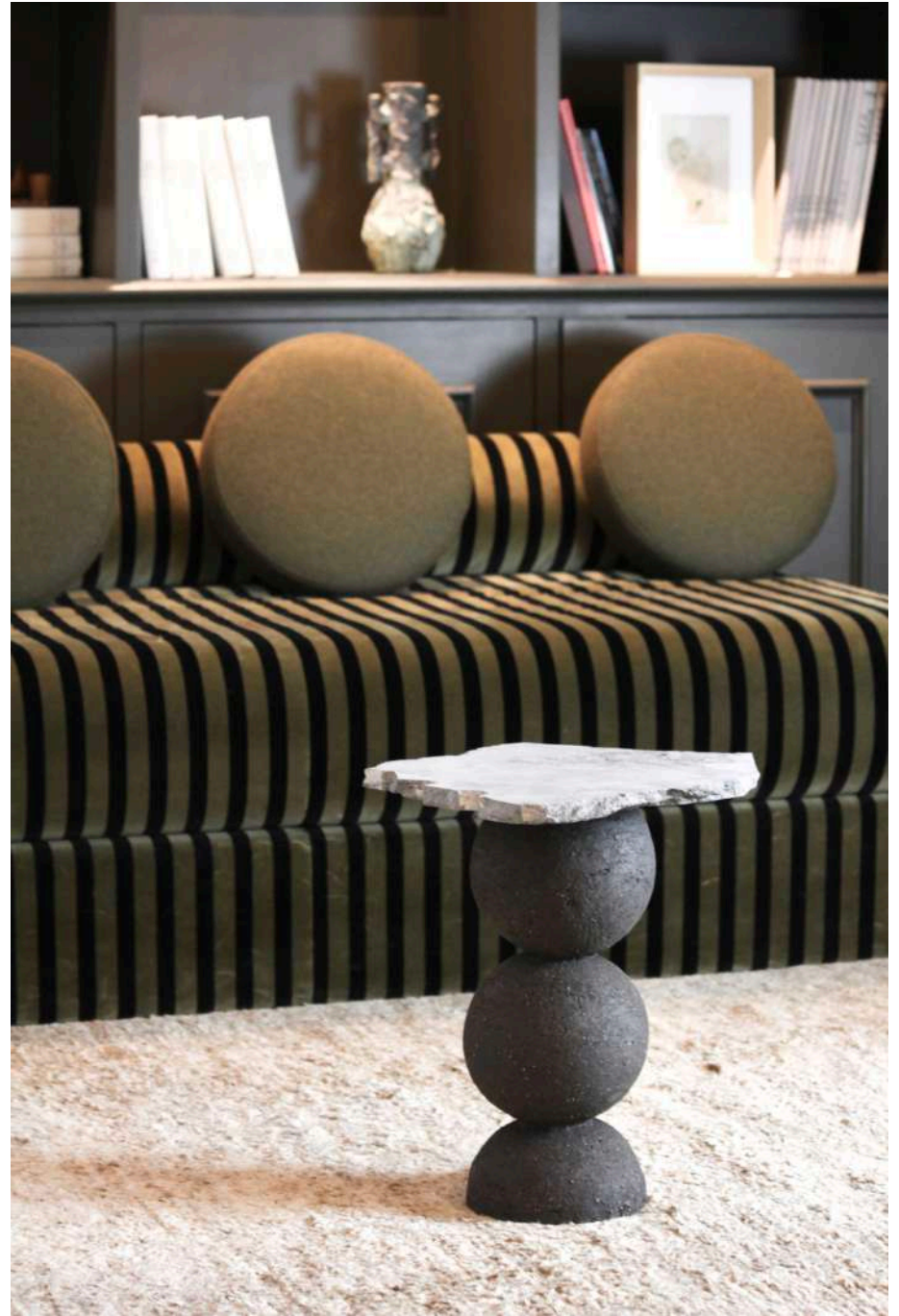



THE TERRA TABLE





THE HÉRAKLÈS CONSOLE

LAMPS



« When I was a child, I used to go for walks late at night to look inside houses. From the road, I could see chandeliers, hanging lights illuminating living rooms. There, under my astonished eyes, objects came to life. »

THE ISTA LAMP



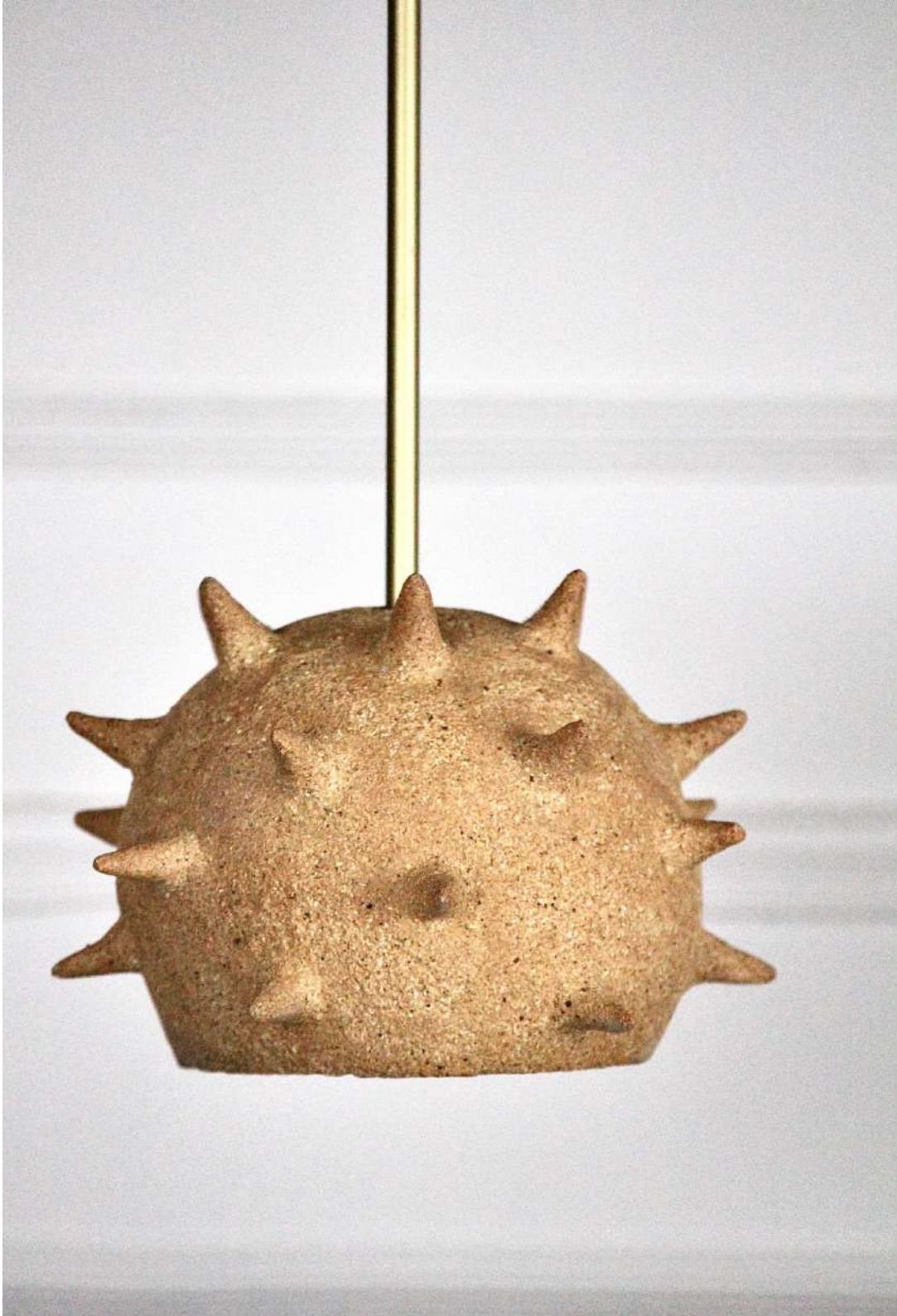

THE HANGING LIGHT JÚPITER



THE WALL LAMP JÚPITER





CANDLESTICKS



« It's only a short step from angel to demon.
- Not sure I understand, I replied.
- Who, in winter, warms our clouds and lights up our faces ?
continued the angel. »





THE TORE CANDLESTICK



THE RIO CANDLESTICK



THE JUPITER CANDLESTICK



THE DALI CANDLESTICK

MADE-TO-MEASURE

Always looking for new challenges, Alan Louis likes to push back the boundaries of his creativity and his world by offering his signature to private individuals and professionals through the creation of made-to-measure furniture and objects.

« With design, you can break away from standards and imagine infinite rooms. I like to challenge spaces and play with dimensions. »

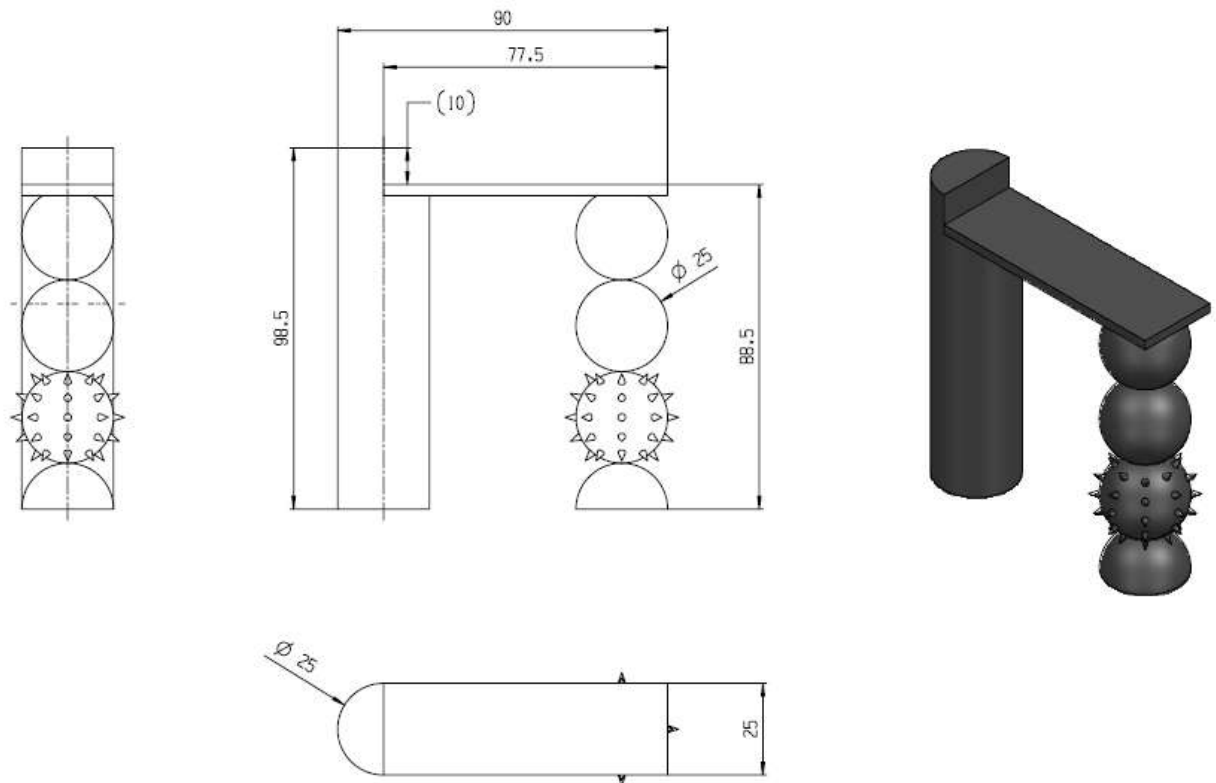

VASES

« Vases to put flowers in, flowers to create vases, for me they are the cradle of the art of ceramics. The most precious jewels come from the earth. I started ceramics so that I could understand the clay, shape it as I wished and extract my ideas from it. »



THE ESTRELA VASE



THE ALMA VASE

THE ESPORÃO VASE

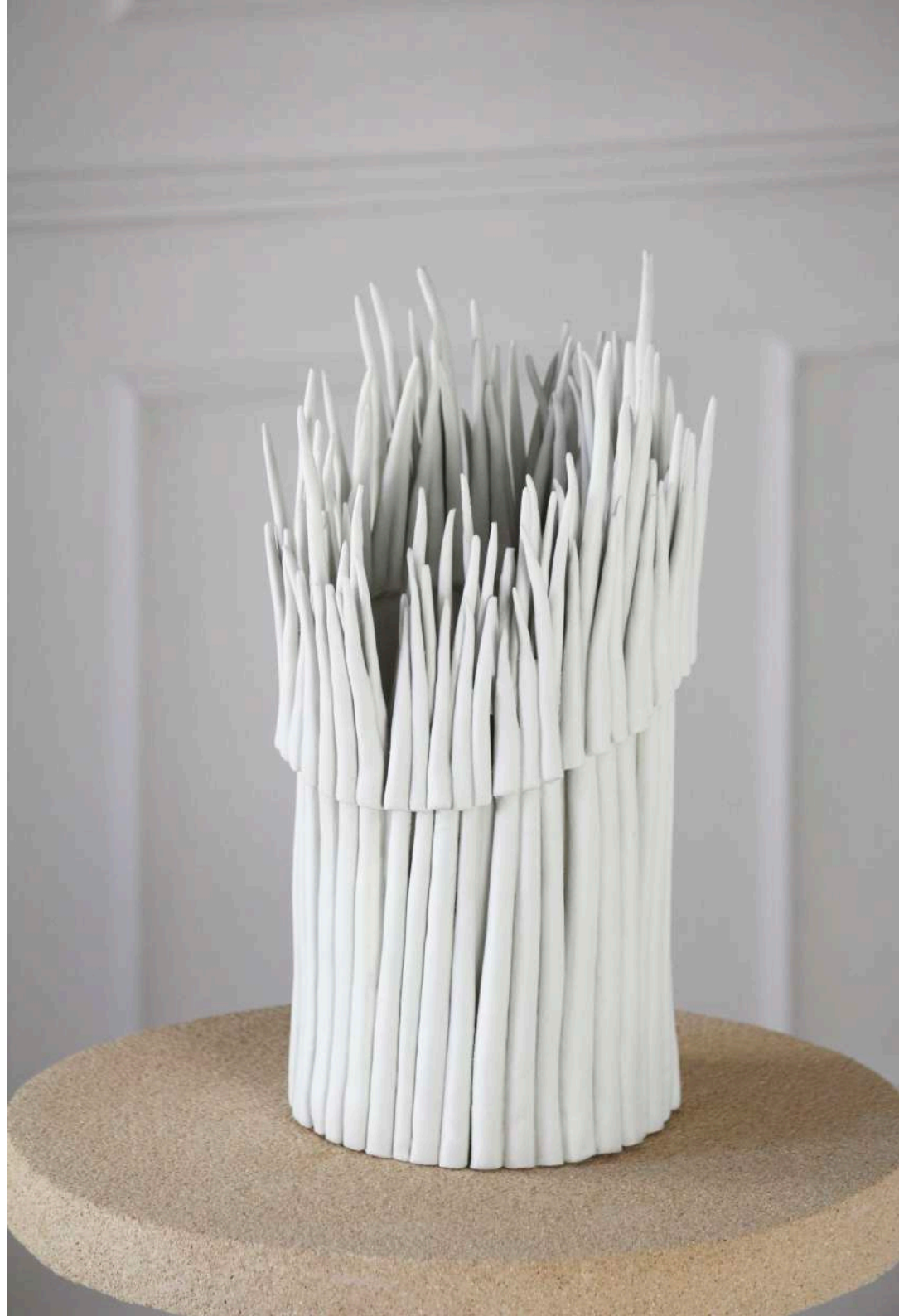



THE ESOSO VASE





THE PREGO VASE



CANDLES



« All those times when I wanted to stop the wind, lock its perfume in a bottle and keep it close to me for eternity. »

The candles are designed to combine traditional craftsmanship with respect for the environment. The fragrances are carefully selected and developed in the land of perfume, in Grasse. Alan Louis has his own version of scented candles, always with a raw, refined look, an allusion to seashells and an invitation to the beach. Handmade by the artist, the pots are made of ceramic, a more or less chamotte stoneware depending on the collection, with an enamelled interior to create a barrier between the wax and the ceramic.

The candles are produced with vegetable waxes (soya/coconut) and a plaited cotton wick. Carefully selected natural scents evoke wood, leather, musk...

LES JARDINS DE LAPA

White stoneware candle - Notes of orange blossom, small seeds of bigarade and neroli. Powdery and musky notes.

ROCHER NOIR

Black stoneware candle - Earthy accords, notes of moss and wood.

22 SEPTEMBRE

Black and red chamotte stoneware candle - Oud wood is accompanied by notes of saffron, Moroccan cedar and tonka bean.

GIGI

Sand stoneware candle - Notes of fig, cedar and rose.

LES AMOURS D'OLIBAN

Limited Edition

Unbleached chamotte stoneware candle with a gold pearl.
Notes of leather, resin, thyme and midnight jasmine.

Average wax weight: 320 gr

Burning time: 55 à 65 hours (indicative burning time)



L'APPARTEMENT

by ALAN LOUIS

This quest to explore and nourish his work prompted Alan Louis to move to Lisbon. He completely renovated a 1930 flat where he now lives and has his studio. An island of calm on the heights of the river Tagus.

« I missed the fever of long summer days. If effort, self-questioning and sometimes despair are necessary for creation, so are the sun, the gentle lifestyle and the poetry of a place. I imagine my paintings and objects living through their settings. I sometimes project them here and there, in different interiors. »

« My parents owned an old house in the country that used to be an annexe, a sort of barn. It had a dirt floor. They turned it into a sublime farmhouse. I was very young when I tried my hand at restoration work by helping my father, from demolishing the walls to restructuring the space. Then came the finishing touches, for which I accompanied my mother, sanding, plastering and painting. I've always had an attraction for decoration and design. Feeling good at home is important to me. The atmosphere should be conducive to the development of the mind and creativity. I started to take an interest in decoration quite a long time ago, I think. I remember advising my mother on objects, furniture, colours and textures to suit the space. For me, it's always been an intuitive process. »





© FRENCHIE CRISTOFALINI



In Lisbon's Lapa district, he is renovating his flat in the style of his works of art. He has turned it into a relaxing setting that reflects his personality. The modern, the raw and the old harmonise, and the place is coloured in light, organic shades, creating a pure atmosphere conducive to relaxation. The palette extends from pure white to luminous ochre, accented with a few delicate touches of gold to keep things natural and draw the eye to every detail of his world.

Two balconies decorated with exotic plants, antiques and symbolic animals in every room complete the story of this flat and invite you to travel. These include a 150-year-old Chinese screen turned into a headboard and antique vases such as an 18th-century « Sang de boeuf Qing ». There are also objects by carefully selected designers including Michael Anastassiades, Sarah Lavoine and Nicolas Breves. There's also furniture by G-Plan, creations by Portuguese designer Olaio from the 1930s, Italian Nicolazzi taps and Buster & Punch handles. A marble worktop and tables designed by Alan Louis and made in Portugal are a tribute to the stone.



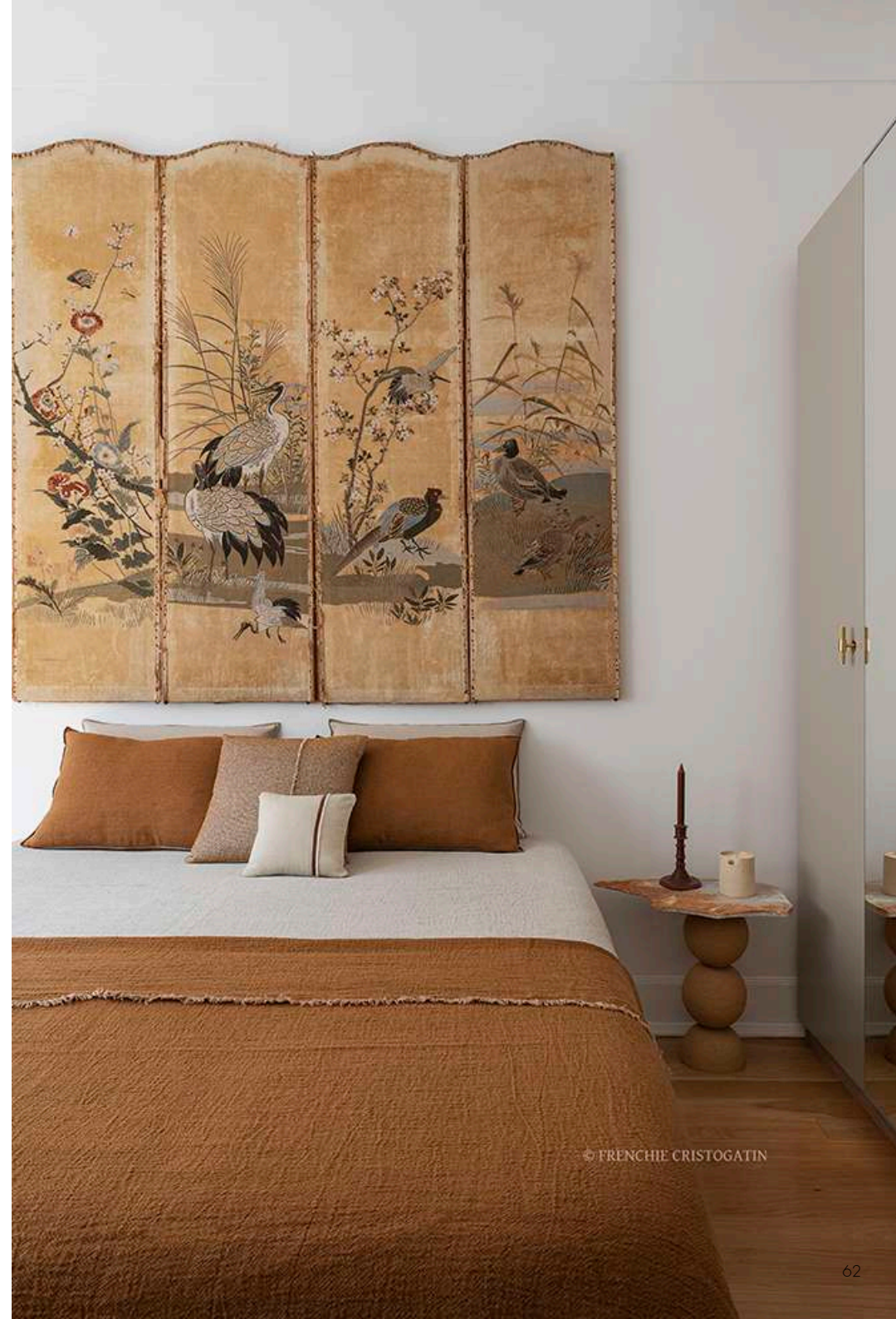

OTHER DECORATION AND RENOVATION PROJECTS

Since autumn 2022, Alan Louis has been continuing to explore his passion for renovation and decoration. He is restructuring and renovating an old house built in 1950 in the Portuguese countryside, the Ribatejo, a region still discreetly surrounded by cork oaks and eucalyptus forests.

In 2023, his creativity will be brought to bear on another project, a triplex in a historic building and a house with a garden in Brittany, a stone's throw from the pink granite coast, which he is particularly fond of for its pastel-coloured heaps of rock.



THE ARTIST



From an early age, Alan Louis discovered an affinity with nature. He was inspired by the countryside in which he grew up, while drawing and painting together took on an important role in his life. What captivated him were the nuances of the past, the colours that he cleverly blended to create infinite watercolours. At school, he imagined elaborate and singular shapes and silhouettes: his sense of detail was already there.

Later, it was to the sea that he finally devoted himself, studying to become an officer in the Merchant Navy. In his suitcase, his pencils accompanied him on his travels. Little by little, the artist realised that the career he had chosen would not be his life, and that drawing was a remedy for everything.

Exploring his creativity became essential.

ANIMALS

The contemporary bestiary has combined with his fascination for the gaze, enabling him to create works based around animals and their confidences. Paintings capable of interacting without words. His subjects tell stories, reveal emotions, speak of what time gives us and what it takes away. All in a universal language.

www.alanlouisparis.com
@alanlouisparis

COMMUNICATION & DISTRIBUTION CONTACT

20th
MARCH

Christophe Kerambrun & Sophie Blanzaco
rp@20ofmarch.com
+33626542897
+33665012616